



ASCENT™ Aluminium Walkways

For Standing Seam Roofing Systems

Safety Fabrications has a long history of working within the construction industry providing permanent safe access walkways for inspection, repair and maintenance on pitched and flat roofs.

Industrial Knowledge and Heritage

Safety Fabrications is based in the heartland of Sheffield's manufacturing industry and has a philosophy of supporting local suppliers. We work closely with them using their experience and skills to meet the exacting time and quality standards the construction industry demands.

Design Principles

The Ascent range of aluminium walkways is a standardised modular system allowing specifiers to design compliant walkways for access on all major manufacturers and their standing seam roofing configurations. A guardrail system can be added to either one or both sides of walkway.

Compliance

Safety Fabrications Aluminium walkways are manufactured in accordance with CE certification. They are tested to BS EN 516:2006 Class 1 Type C meeting all the Health and Safety requirements demanded.

The range of standard componentry fixes to roofs of differing slope and seam widths. The walkway can be configured with a handrail to withstand a loading of either 0.36 kN (general duty) or 0.74 kN (heavy duty) and can be supplied with an optional toeboard if required. The Ascent walkway is unique in that it can achieve these loadings without the need for additional bracing—allowing the walkway to be placed right up against the area to be accessed.



ASCENT™

Aluminium Walkways

SPECIFICATION DETAILS
FOR STANDING SEAM
ROOFING SYSTEMS

INSTALLATION GUIDE; Laying walkways across the fall of the roof on roof pitches less than 3°

- Set clamps in a line, spaced to a maximum of 1600 mm for medium duty and maximum of 800 mm for heavy duty. Tighten M6 bolt to 5.9 Nm.
- Use self drilling screws to fix walkways to the clamps. Tighten to 6 Nm.
- To join two walkway sections use the joining channel.
- Fix joining channel to walkway using two self drilling screws but to one walkway only—provides flexibility for metal expansion. Tighten screw to 6 Nm.

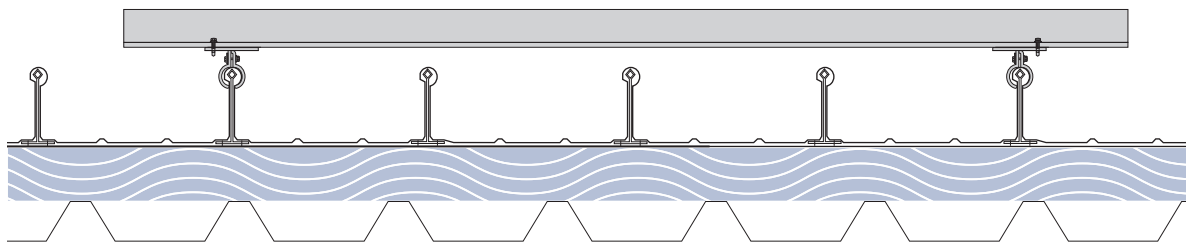
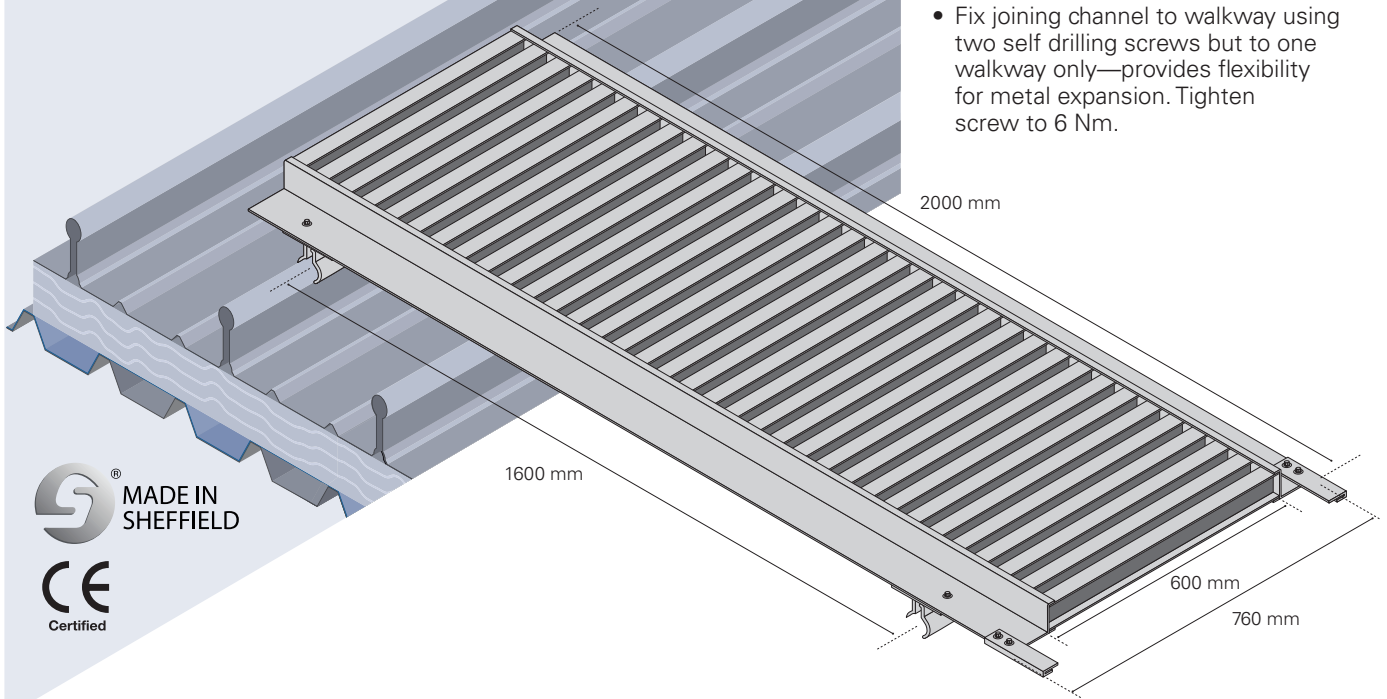

Fixing Detail

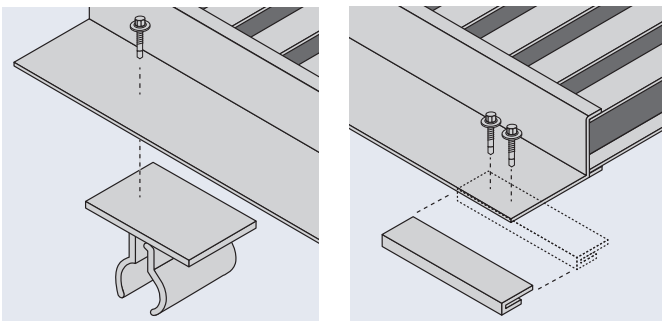

Components

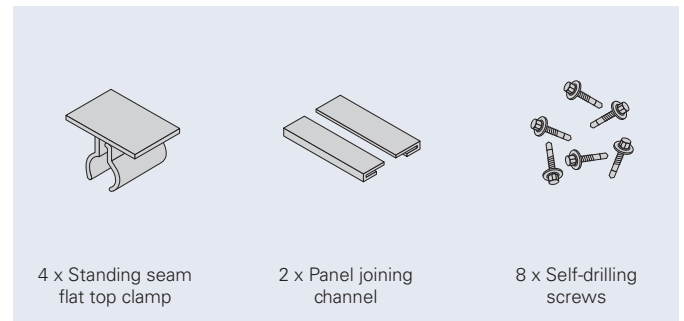

Expansion Joints: An expansion joint of 5 mm must be incorporated in every walkway made from joined panels 6000 mm in length.

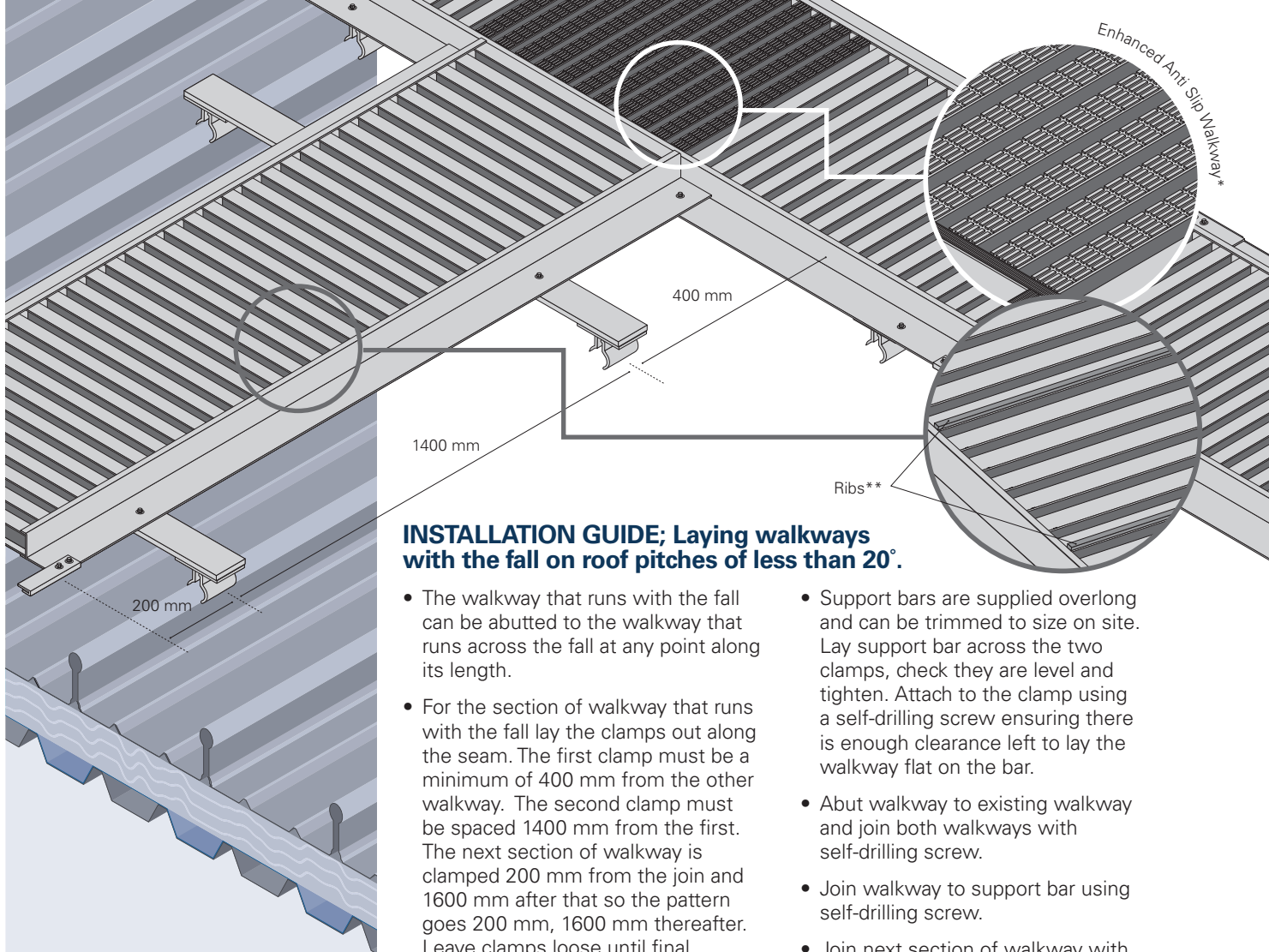

INSTALLATION GUIDE; Laying walkways with the fall on roof pitches of less than 20°.

- The walkway that runs with the fall can be abutted to the walkway that runs across the fall at any point along its length.
- For the section of walkway that runs with the fall lay the clamps out along the seam. The first clamp must be a minimum of 400 mm from the other walkway. The second clamp must be spaced 1400 mm from the first. The next section of walkway is clamped 200 mm from the join and 1600 mm after that so the pattern goes 200 mm, 1600 mm thereafter. Leave clamps loose until final position can be determined.
- Support bars are supplied overlong and can be trimmed to size on site. Lay support bar across the two clamps, check they are level and tighten. Attach to the clamp using a self-drilling screw ensuring there is enough clearance left to lay the walkway flat on the bar.
- Abut walkway to existing walkway and join both walkways with self-drilling screw.
- Join walkway to support bar using self-drilling screw.
- Join next section of walkway with panel joining channel as described on page 2.

ASCENT™ Aluminium Walkways

SPECIFICATION DETAILS FOR STANDING SEAM ROOFING SYSTEMS

MADE IN SHEFFIELD



Components

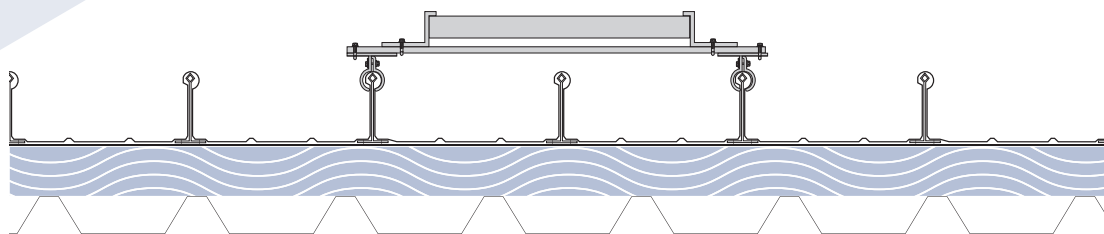
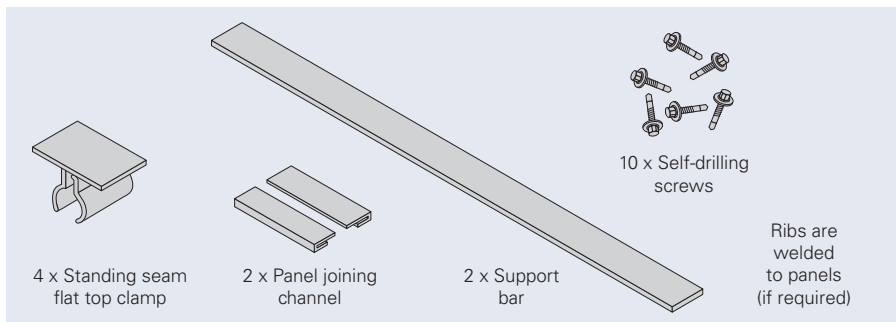

Fixing Detail

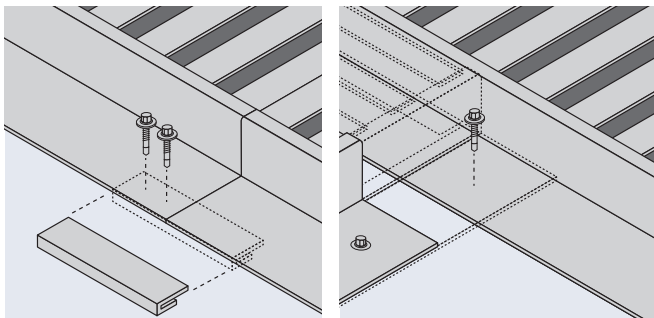

Upon completion check all fixings are to the required torque settings: Self drilling screws 6 Nm / Clamp bolts 5.9 Nm

*Enhanced Anti Slip Walkway—slip resistance testing requirement—BS 7976-2:2002+A1:2013 on panel, corner and T-junction configuration. **The walkway can be used as a ramp up to 20°. Up to 10° standard panels are used, over 10° additional ribs are required to increase slip resistance.

ASCENT™ Aluminium Walkways

SPECIFICATION DETAILS
FOR STANDING SEAM
ROOFING SYSTEMS

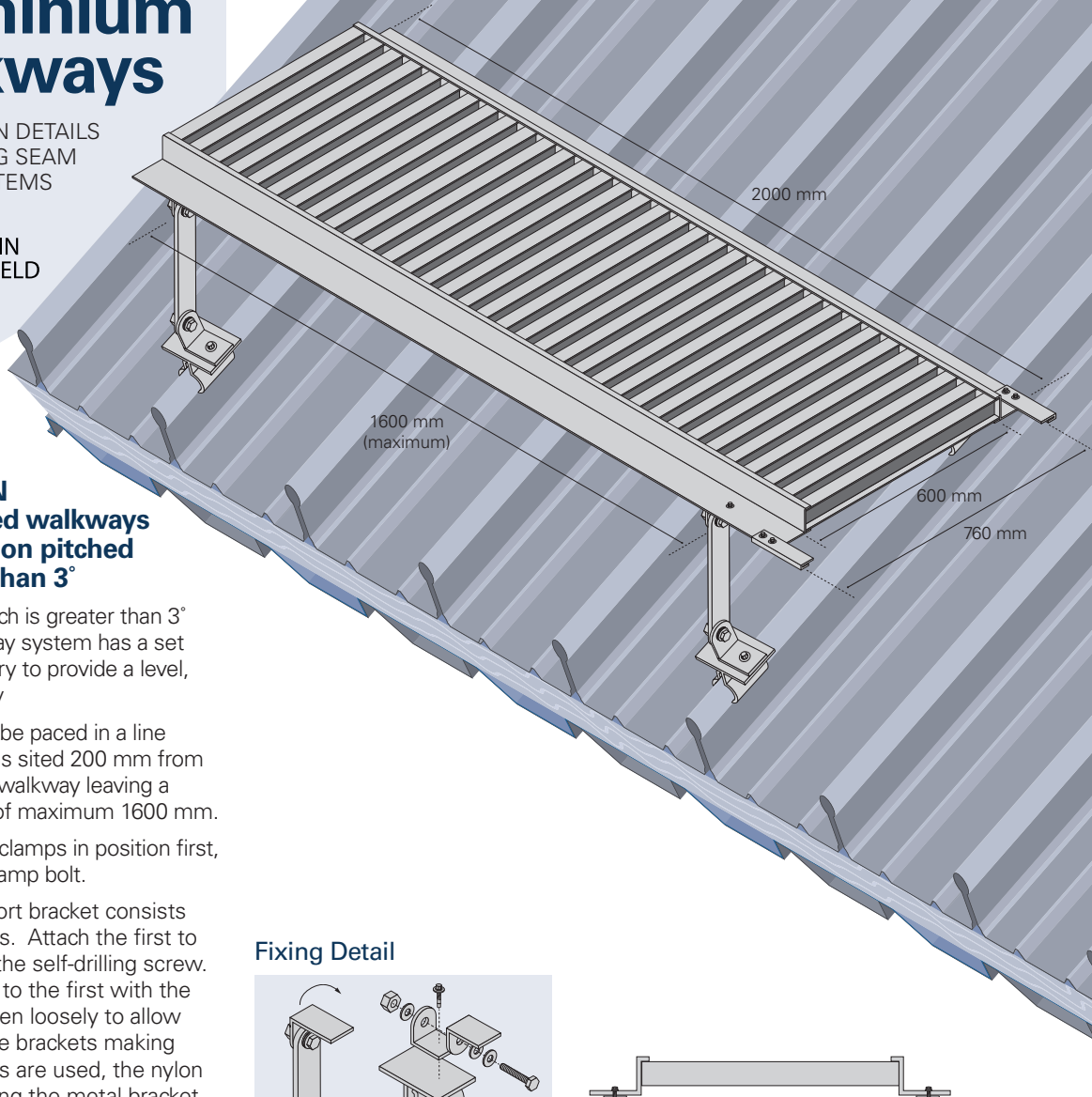

INSTALLATION GUIDE; Levelled walkways across the fall on pitched roofs greater than 3°

Where the roof pitch is greater than 3° the Ascent Walkway system has a set of levelling bracketry to provide a level, compliant walkway

- Clamps need to be paced in a line across the seams sited 200 mm from each end of the walkway leaving a middle spacing of maximum 1600 mm.
- Place the upper clamps in position first, tightening the clamp bolt.
- The upper support bracket consists of x 2 90° angles. Attach the first to the clamp with the self-drilling screw. Bolt the second to the first with the M12 bolts. Tighten loosely to allow movement in the brackets making sure x 4 washers are used, the nylon washer separating the metal bracket and metal washer. Once in the correct position tighten to 50 Nm.
- Bolt the bottom clamp to the seam leaving loose enough to slide the clamp up and down the seam.
- A 90° angle is affixed to the clamp using self-drilling screw and the levelling arm is then bolted to the angle using a M12 bolt. Bolt the top of the levelling arm to another 90° angle. Loosely tighten so that the height of the arm can be adjusted to ensure the walkway can be levelled. Once in the correct position tighten the bolts to 50 Nm.
- Lay the walkway on the 'upper' clamps and temporarily hold in place with suitable clamps. The bottom brackets can then be manipulated by sliding along the seam and the levelling arm adjusted to ensure the walkway is level.
- Once level secure the walkway to the clamps using a self-drilling screw.
- Join the next walkway using panel joining channels as previously described.

Fixing Detail

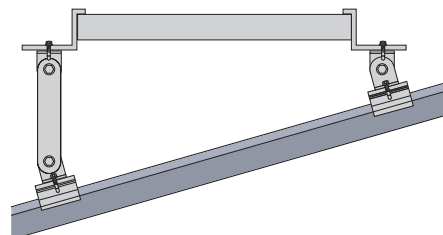
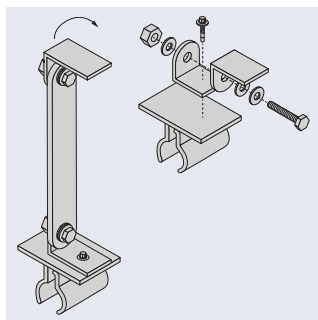

Components

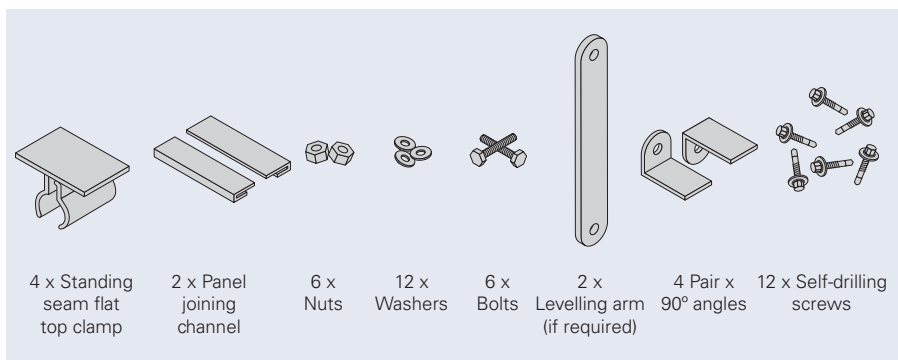

Upon completion check all fixings are to the required torque settings:

Clamp bolts 5.9 Nm / Self-drilling screws 6 Nm / Bolts holding walkway arms 50 Nm

ASCENT™ Aluminium Walkways

SPECIFICATION DETAILS
FOR STANDING SEAM
ROOFING SYSTEMS

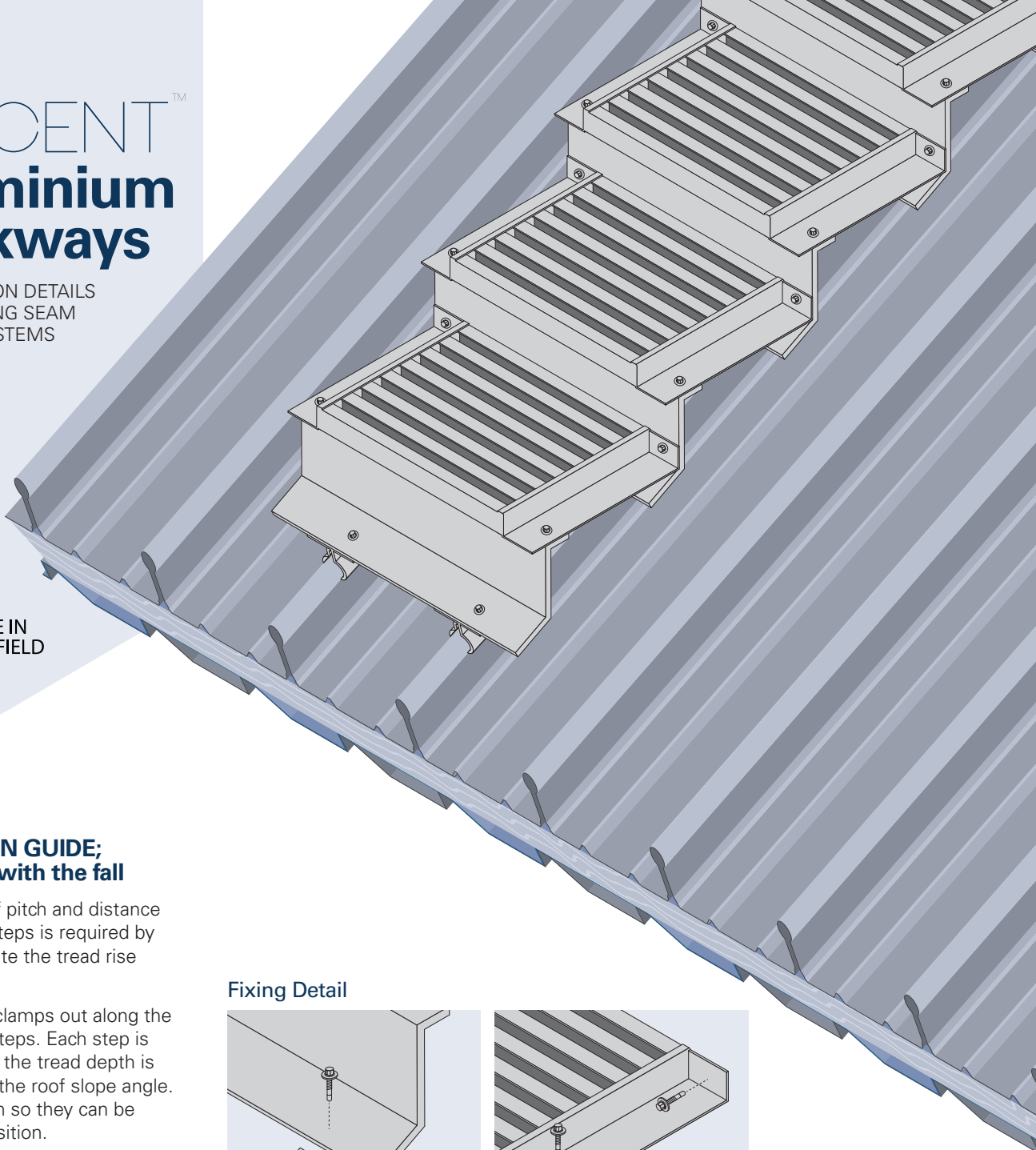

INSTALLATION GUIDE; Laying steps with the fall

The angle of roof pitch and distance covered by the steps is required by Ascent to calculate the tread rise and going.

- Lay the fixing clamps out along the length of the steps. Each step is 600 mm wide, the tread depth is dependent on the roof slope angle. Loosely tighten so they can be moved into position.
- Use x 2 self-drilling screws to fix the riser to the clamp.
- Lay the step on the top of the riser and using a spirit level check the tread is level. Use a self-drilling screw to fix the step to the next riser once the step is level.
- Repeat process for the remaining steps.

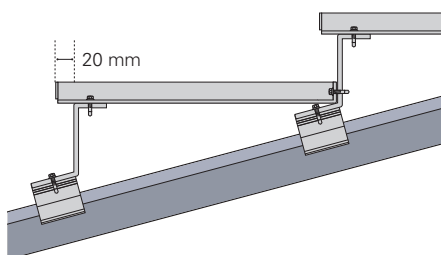

Fixing Detail

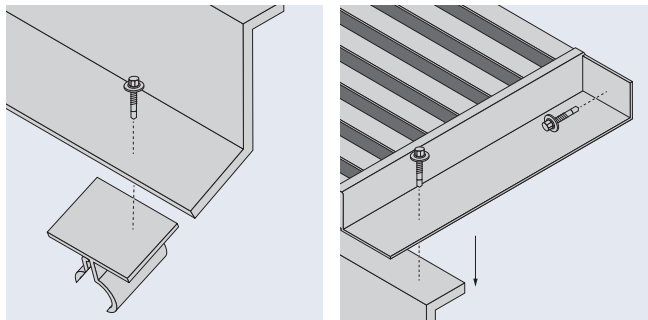

Components

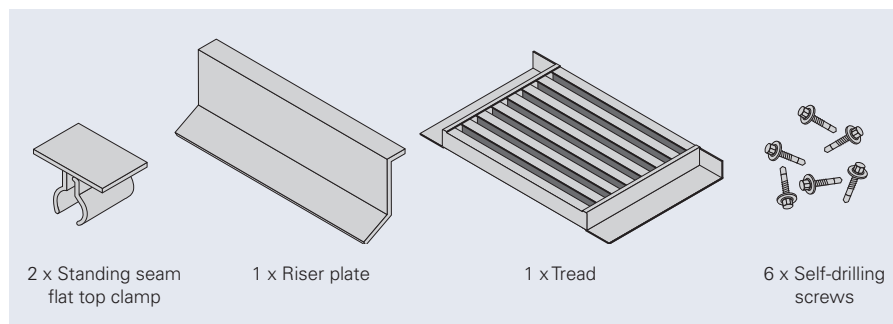

Ensure everything is tightened to correct torque settings:

Self-drilling screws 6 Nm /Clamp bolts 5.9 Nm

ASCENT™ Aluminium Walkways with Guardrail

SPECIFICATION DETAILS
FOR STANDING SEAM
ROOFING SYSTEMS

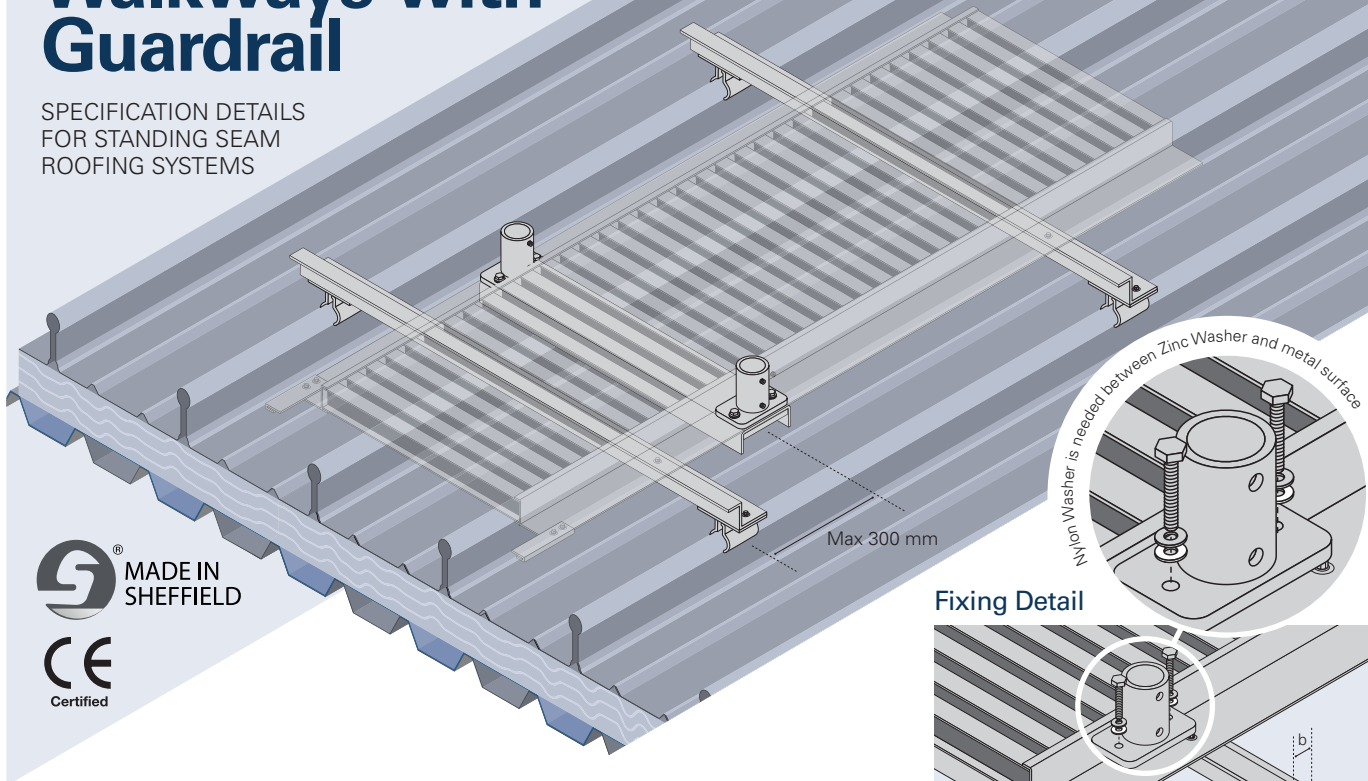

Fixing Detail

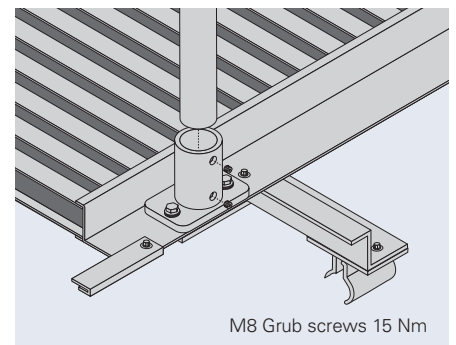
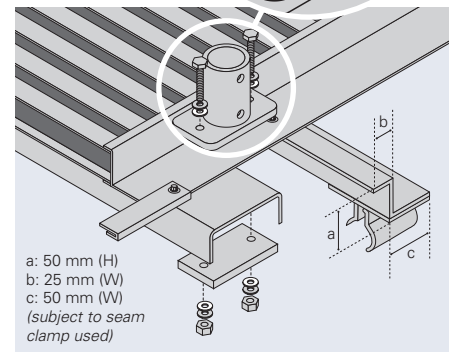

INSTALLATION GUIDE; Fixing aluminium guardrail walkway

- Loosely affix the seam clamps onto roof.
- Using self drilling screws affix the Z-sections to the top of seam clamps. Max 6 KN torque.
- Fit channel to underside of walkway using the M12 bolts, ensuring packer is in place beneath walkway and handrail base above.
- Using self drilling screws affix the walkway panel onto the Z sections, ensuring the handrail base is no more than 300 mm from the Z section.
- Place the post supports a maximum of 300 mm from the fixing point to the roof. The stanchion centres must not be more than 2000 mm apart.
- Hold support post in place with suitable clamps, drill through walkway.
- Slide support channel under the walkway, put packer in place and tighten post support with M12 bolts ensuring nylon washer keeps metallic surfaces separated.
- 2000 mm Stanchion centres for 0.36kN Handrail.

Components

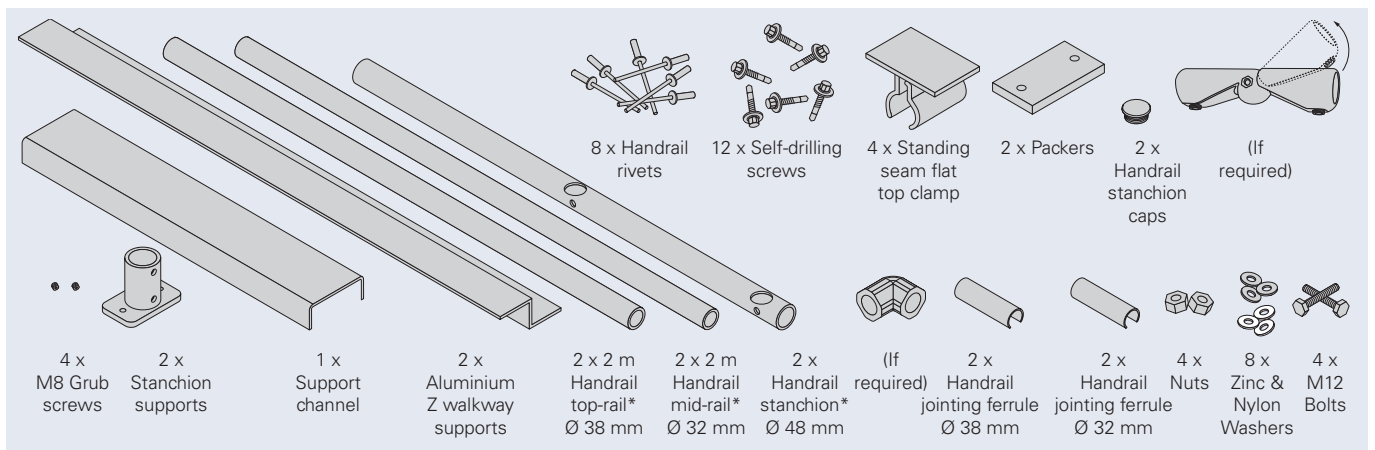

*Assuming handrail to both sides

- 1000 mm Stanchion centres for 0.74kN Handrail.
- Maximum 1200 mm stanchion centres on corners.
- Drop the stanchion into the post supports and loosely tighten with x 2 M8 grub screws.
- Slide both rails in place and use joining rivet to fix to stanchion.
- Join the rails with jointing ferrule riveting on one side only to allow for metal expansion.
- Tighten the M8 grub screws.
- Put a rubber bung in the top of the stanchion and each of the guardrail ends.
- No toeboard is shown. A 100 mm toeboard system is available if required.

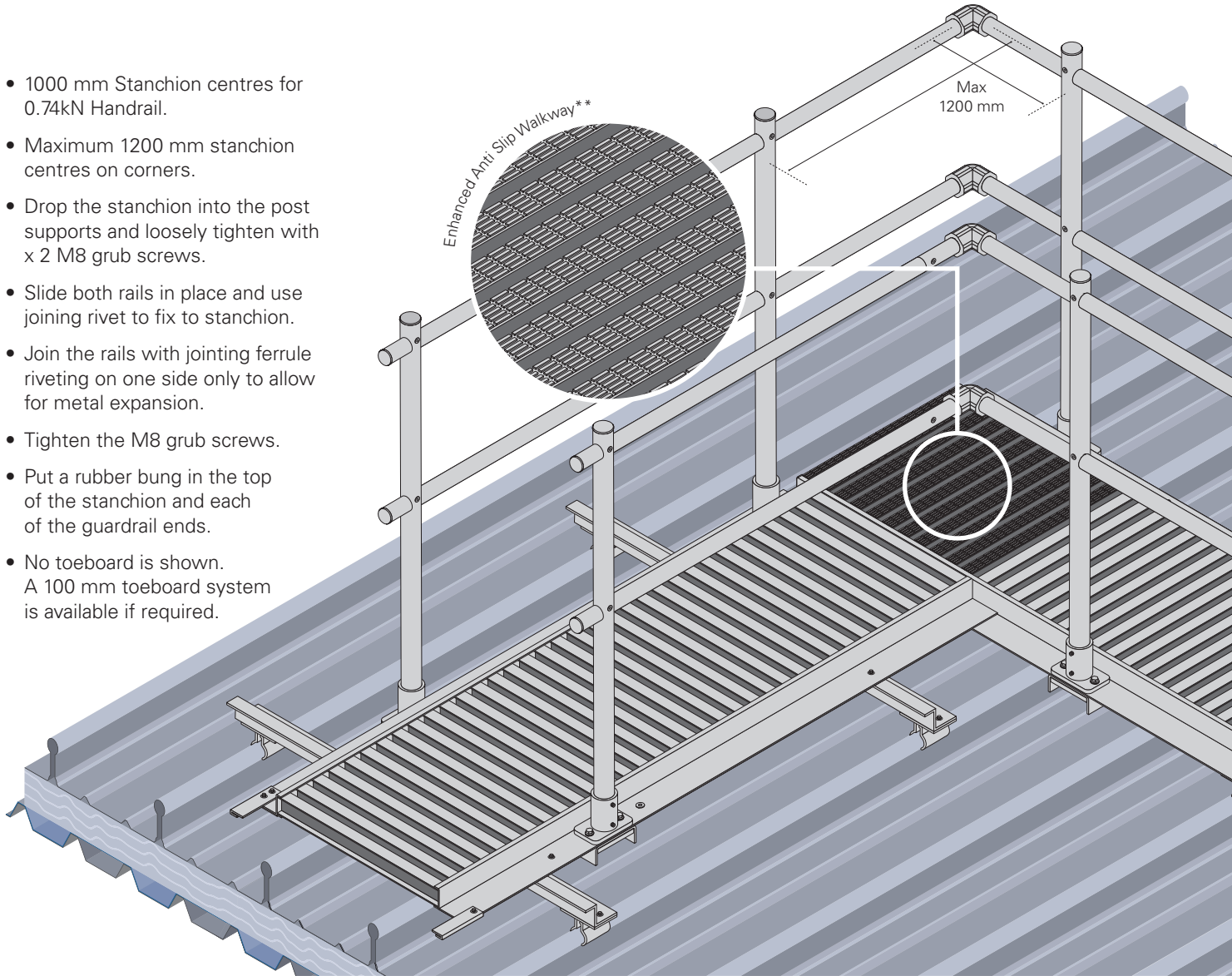

Guardrail closed end detail

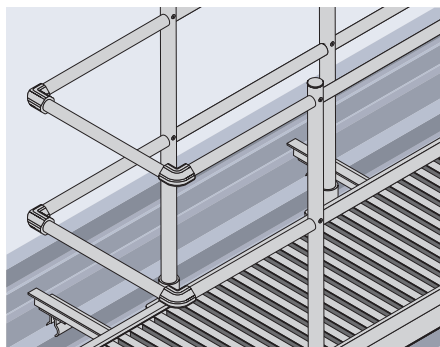

Guardrail open end detail

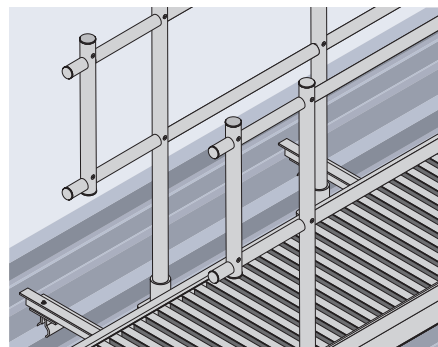

Guardrail wall fix detail

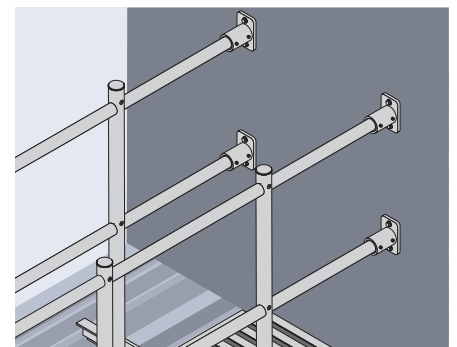

Ensure everything is tightened to correct torque settings:

- Self drill screws 6 Nm / Grub screws on tube fittings 29 Nm / Handrail stanchion grub screws 15 Nm / M12 bolts 50 Nm / Standing seam clamp bolt 5.9 Nm / Bulb rivets with rivet tool

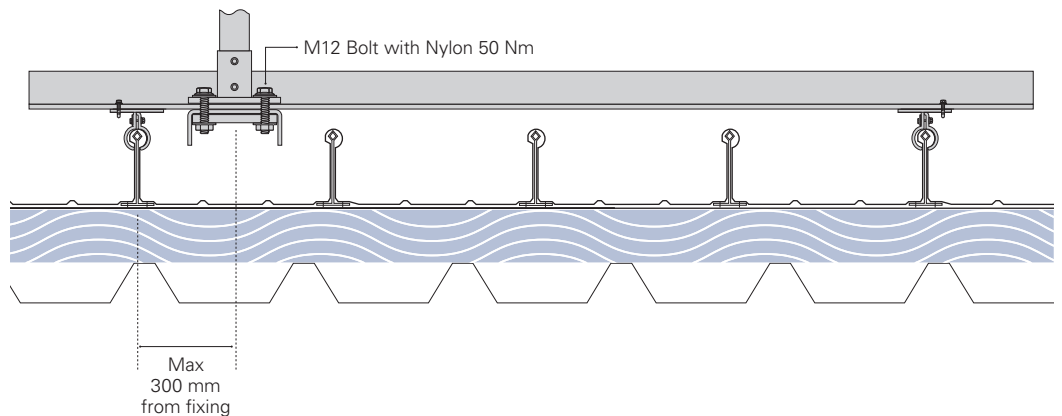

**Enhanced Anti Slip Walkway—slip resistance testing requirement—BS 7976-2:2002+A1:2013 on panel, corner and T-junction configuration.

