



ASCENT™ Step Unit

Simple Solutions for Rooftop Access

Safety Fabrications has a long history of working within the construction industry providing permanent safe access for inspection, repair and maintenance on pitched and flat roofs. Bridging parapet walls, heating ducts, rooftop valleys and external rooftop barriers often requires complex bridging systems. Safety fabrications have simplified the process with a set of modular componentry that easily slots together to allow safe access.

Industrial Knowledge and Heritage

In the heartland of Sheffield's steel industry local based component and raw material suppliers are vital to Safety Fabrications ability to design and manufacture quality products in the timeframes that the construction industry demands.

Design Principles

Ascent™ step units can be manufactured from either Galvanised Mild Steel or Aluminium offering the on-site adjustment to facilitate easy installation giving both safety and finished appearance of a bespoke product.

Ascent™ step units are available as either Up & Onto or Up & Over and are complemented with a range of platforms to clear your obstruction and are supplied with freestanding feet enabling a safe and secure fit without roof penetration.

Handrails, all fixings and feet are included to cover heights up to 1750mm and platform lengths up to 2500mm.

Purpose of this Document

Design and installation guidance is provided with this brochure and general arrangement drawings are provided with each installation which is supplied flat packed.

Compliance

Ascent™ step units are designed in accordance with BS EN ISO 14122-1:2001 + A1:2010 and Building Regulations Part K; 2013. Manufactured in accordance with BS EN ISO 3834-2:2005 & BS EN 1090-1:2009 + A1:2011 & 2:2008 CE Marked.



Step Unit Up & Onto Step Unit

DESIGN SPECIFICATION

To create the Up and Onto Step Unit all that we require from you is the height, length, material and base fixing detail (roof type) of the unit as shown in the schematic. We can then quote, manufacture and deliver flat packed to site ready for installation.

Key Design Principles

WHAT WE WILL NEED TO KNOW

- What the base fixing is – Is it a flat or pitched roof at the base? Are freestanding feet or a spreader plate required? (*Fixings to structure are not included*).
- The height of the obstruction you are looking to clear/height of the item you require access to?
- What is the fixing at the head – does the step unit exit onto a flat roof – what is the roof covering & does it require Free-standing feet or spreader plate? (*Fixings to structure are not included*).
- What length of platform you require at the head?
- Finally, what material type do you want – mild steel galvanised or aluminium?

WHAT YOU NEED TO KNOW

- Ascent Up & Onto step units are designed in accordance with BS EN ISO 14122-1:2001+A1: 2010 and Building Regulations Part K:2013. Manufactured in accordance with BS EN ISO 3834-2:2005 & BS EN 1090-1:2009+A:201 & 2:2008 CE Marked.

Build Advice

The illustration shows a typical Up and Onto Step Unit which provides access from a flat roof at the base to flat roof at the head. The unit shown is freestanding with rubber spreader feet at both base & head.

A method statement detailing the installation process is required. Ensure one has been provided before starting the installation along with necessary access and fall protection equipment.

We recommend building from the bottom up.

Base fixing

- A freestanding step unit will be supplied with either 2 or 4 rubber spreader feet per stair (*depending upon stair height*) and 2 rubber spreader feet for the platform. Build these up & position in approximate final location on the roof. Leave final adjustment until the unit is complete.
- Place the two stair stringers side by side – ensure the stringer is the right way up – this can be done by checking that the 4 holes which join the stringer to the platform are at the top.

Install the bottom & uppermost treads

- When fitting the bottom tread – ensuring the angle bracket which supports the adjustable rubber feet is affixed through the same holes as the tread. The angle to be fitted “toes up”.
- Fit the bottom feet to the now part built up stair unit.

Building the upper platform

- Having placed the material for the platform on the upper roof level start the platform build.
- **To build the platform;** place the pair of angles which form the platform sides approx 600mm apart. Ensure the mitred end of the angle is closer to the roof edge. (*This will join to the stair stringer*).
- Ensure that the angle bracket which supports the adjustable rubber feet is fitted in the second pair of holes at the square cut end of the angle. (*Not the first pair, as they take the handrail stanchion*).
- Fit the feet to the platform sides.
- Offer the platform sides up to the top of the stair stringer & bolt together. You will now have a part built stair & top platform (*without grillage*) framework.
- With the basic frame of the stair/landing in place – adjust the feet using the threaded bar arrangement to ensure the top platform & treads are level. (*Best to do this at this stage as the unit is at its lightest – making adjustment relatively easy*).
- Fit the grillage to the top platform, ensuring to fix the grillage into place with the grillage clips supplied.
- Return to the lower roof & fit the remaining treads to complete the stair unit.

Building the handrail

- First loosely fit the handrail stanchions. Remembering that the stanchions to the platform have a 10mm packer fitted behind them. Having installed the handrail stanchions, fit the handrail tube & D-returns. Ensure internal jointers & all external fittings are fully engaged and the hex grub screws torque tightened to 39 Nm.
- Complete a final level check on treads, platform and handrail stanchions and torque all M12 bolts to 100 Nm.

Using your measurements

A B

we can identify the components that you require

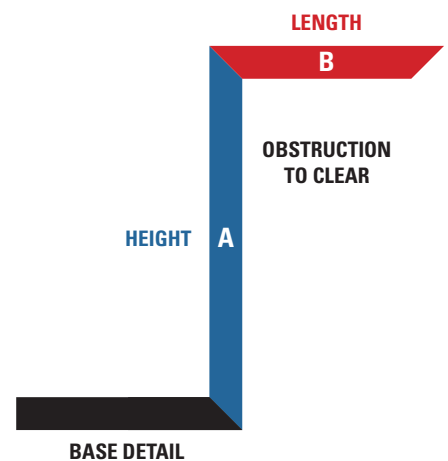

TREADS	HEIGHT A (mm)
1	287 - 407
2	432 - 627
3	652 - 847
4	872 - 1067
5	1092 - 1287
6	1312 - 1512
7	1533 - 1727

PART	UP & ONTO PLATFORM up to (mm)
1	502
2	1002
3	1502
4	2002
5	

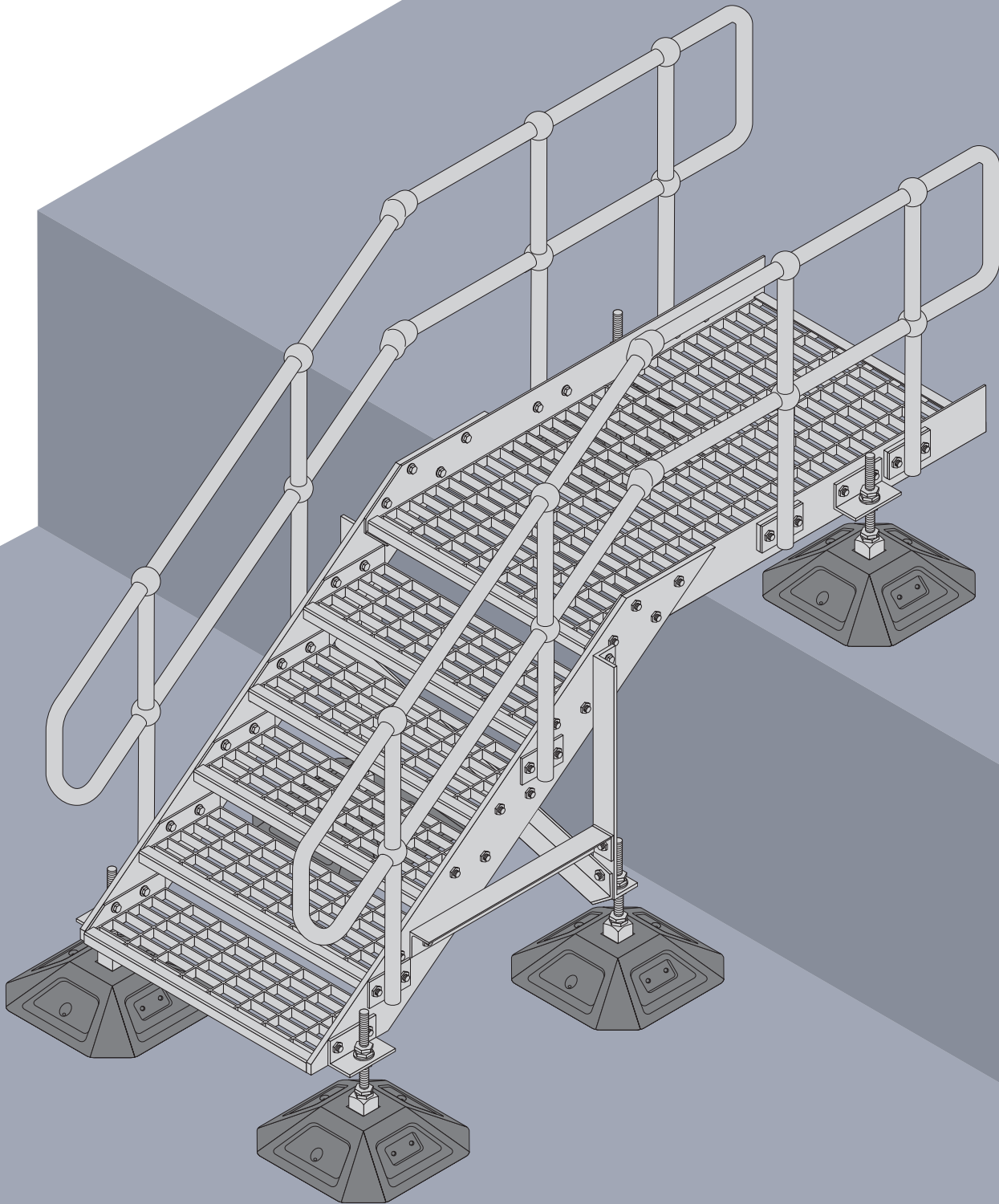

Step Unit Up and Over Step Unit

DESIGN SPECIFICATION

To create the Up and Over Step Unit all that we require from you is the height & width of the obstruction you require to step over, the material and roof type. We can then quote, manufacture and deliver flat packed to site ready for installation.

Key Design Principles

WHAT WE WILL NEED TO KNOW

- What the base fixing is – Is it a flat or pitched roof at the base? Are freestanding feet or a spreader plate required? (*Fixings to structure are not included*).
- The height of the obstruction?
- The width of the obstruction?
- Finally, what material type do you want – mild steel galvanised or aluminium?

WHAT YOU NEED TO KNOW

- Ascent Up & Over step units are designed in accordance with BS EN ISO 14122-1:2001+A1:2010 and Building Regulations Part K:2013. Manufactured in accordance with BS EN ISO 3834-2:2005 & BS EN 1090-1:2009+A:201 & 2:2008 CE Marked.

Build Advice

The illustration shows a typical Up and Over Step Unit which provides access over pipework on a flat roof. The unit shown is freestanding with rubber spreader feet at the base of both stairs. (*The unit will be supplied with either 2 or 4 rubber spreader feet per stair depending upon stair height*).

A method statement detailing the installation process is required. Ensure one has been provided before starting the installation along with necessary access and fall protection equipment.

We recommend building from the bottom up.

Base fixing

- A freestanding step unit will be supplied with either 4 or 8 rubber spreader feet. Build these up & position in approximate final location on the roof. Leave final adjustment until the unit is complete.
- Place the two stair stringers side by side – ensure the stringer is the right way up – this can be done by checking that the 4 holes which join the stringer to the platform are at the top.

Install the bottom & uppermost treads

- When fitting the bottom tread – ensuring the angle bracket which supports the adjustable rubber feet is affixed through the same holes as the tread. The angle to be fitted “toes up”.

- Fit the bottom feet to the now part built up stair unit.
- Repeat for the opposite stair.
- Now, take the two angles which form the sides of the platform and affix them to one set of the part built stairs – affix the connection bolt, but do not overtighten.
- You will now have a part built stair & top platform (*without grillage*) framework.
- The next stage in the build process is the most awkward as it involves joining the part built stair & platform to the opposing stair. If possible place some protection on top of the obstruction (*pipework/ductwork/parapet*) and lay the stair/platform on to it. Then join the opposing stair to it.
- With the basic frame of the stair/landing in place – adjust the feet using the threaded bar arrangement to ensure the platform & treads are level. (*Best to do this at this stage as the unit is at its lightest – making adjustment relatively easy*).
- Fit the grillage to the top platform, ensuring to fix the grillage into place with the grillage clips supplied.
- Fit the remaining treads to complete the stair unit.

Fixing the handrail

- First loosely fit the handrail stanchions. Remembering that the stanchions to the platform have a 10mm packer fitted behind them. Having installed the handrail stanchions, fit the handrail tube & D-returns. Ensure internal jointers & all external fittings are fully engaged and the hex grub screws torque tightened to 39 Nm.
- Complete a final level check on treads, platform and handrail stanchions and torque all M12 bolts to 100 Nm.

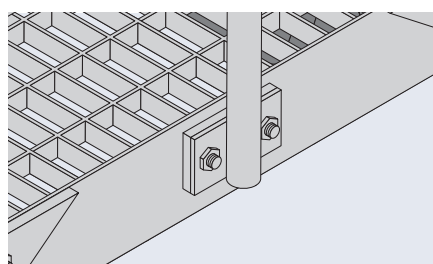

Handrail stanchions with 10 mm Packer

Using your measurements

A **B** **C**
we can identify the components that you require

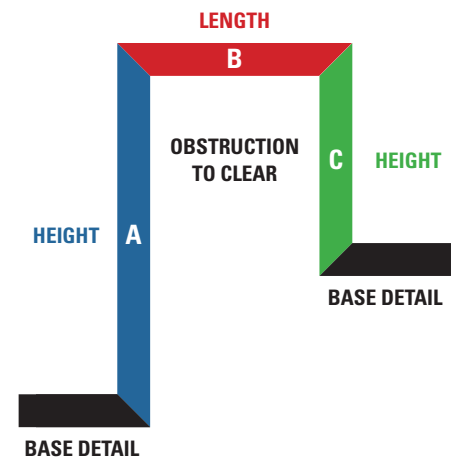

TREADS	HEIGHT A (mm)	HEIGHT C (mm)
1	287 - 407	292 - 407
2	432 - 627	432 - 627
3	652 - 847	652 - 847
4	872 - 1067	872 - 1067
5	1092 - 1287	1092 - 1287
6	1312 - 1512	1312 - 1512
7	1533 - 1727	1533 - 1727

PART	UP & OVERPLATFORM up to (mm)
1	538
2	1038
3	1538
4	2038
5	2538

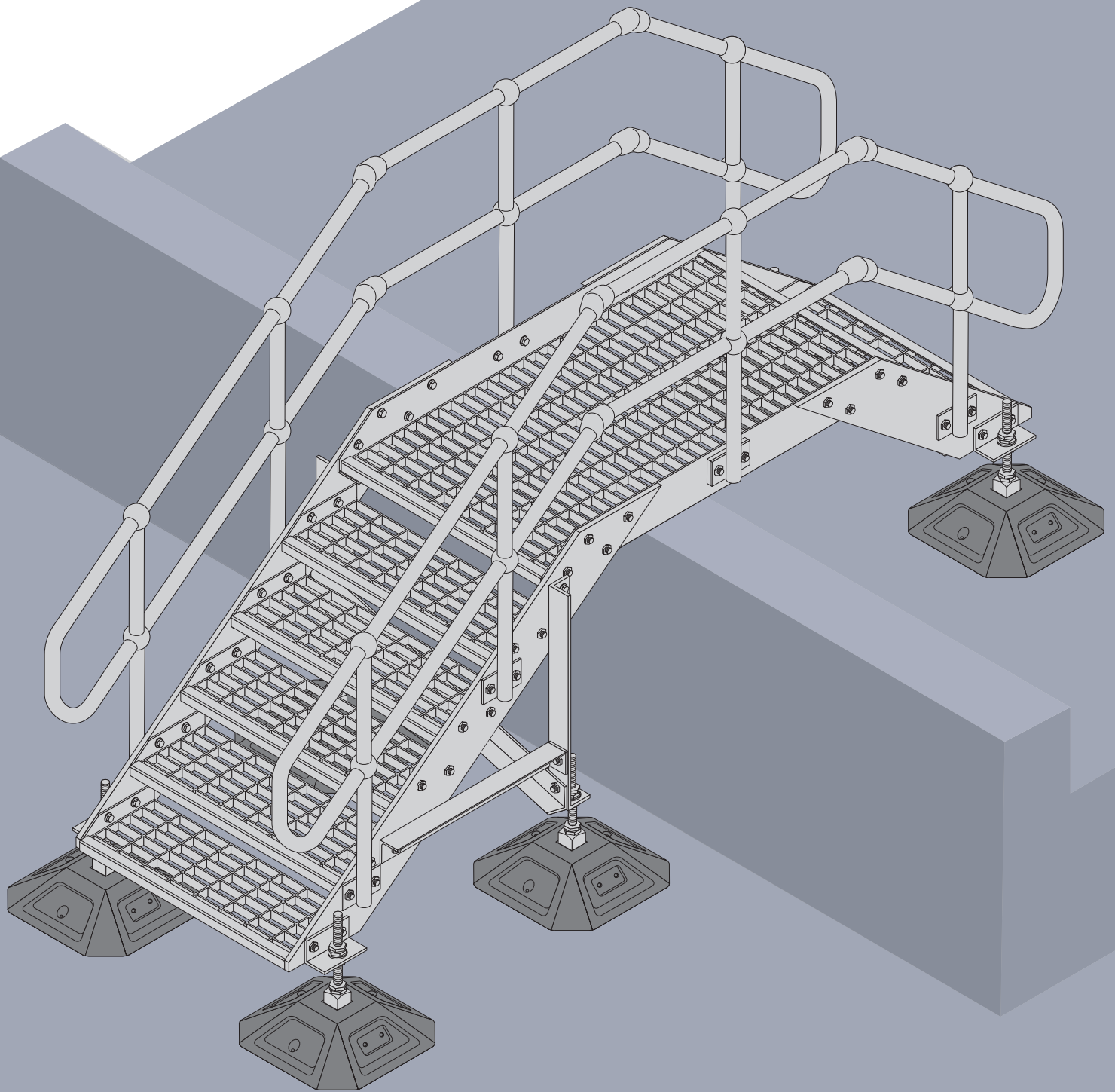

Step Unit Low Level Bridge Platform

DESIGN SPECIFICATION

To create the Low Level Bridge Platform all that we require from you is the height & width of the obstruction you require to clear, plus the material type and roof type. We can then quote, manufacture and deliver flat packed to site ready for installation.

Key Design Principles

WHAT WE WILL NEED TO KNOW

- What the base fixing is – Is it a flat or pitched roof at the base? Are freestanding feet or a spreader plate required? (*Fixings to structure are not included*).
- The height of the obstruction?
- The width of the obstruction?
- Finally, what material type do you want – mild steel galvanised or aluminium?

WHAT YOU NEED TO KNOW

- Ascent Low Level Bridge Units are designed in accordance with BS EN ISO 14122-1:2001+A1:2010 and Building Regulations Part K:2013. Manufactured in accordance with BS EN ISO 3834-2:2005 & BS EN 1090-1:2009+A:201 & 2:2008 CE Marked.

Build Advice

The illustration shows a typical Low Level Bridge Platform which provides access over pipework on a flat roof. The unit shown is freestanding with rubber spreader feet.

A method statement detailing the installation process is required. Ensure one has been provided before starting the installation along with necessary access and fall protection equipment.

We recommend building from the bottom up.

Base fixing

- A Bridge Unit will be supplied with 4 rubber spreader feet. Build these up & position in approximate final location on the roof. Leave final adjustment until the unit is complete.
- Place the two stair stringers side by side – ensure the stringer is the right way up – this can be done by checking that the 4 holes which join the stringer to the platform are at the top.

Install the bottom treads.

- When fitting the bottom tread – ensuring the angle bracket which supports the adjustable rubber feet is affixed through the same holes as the tread. The angle to be fitted “toes up”.
- Fit the bottom feet to the now part built up stair unit.
- Repeat for the opposite stair.
- Now, take the two angles which form the sides of the platform and affix them to one set of the part built stairs – affix the connection bolts, but do not overtighten.
- You will now have a part built stair & platform (*without grillage*) framework.
- The next stage in the build process is the most awkward as it involves joining the part built stair & platform to the opposing stair. If possible place some protection on top of the obstruction (*pipework/ductwork/parapet*) and lay the stair/platform on to it. Then join the opposing stair to it.
- With the basic frame of the stair/landing in place – adjust the feet using the threaded bar arrangement to ensure the platform & treads are level. (*Best to do this at this stage as the unit is at its lightest – making adjustment relatively easy*).
- Fit the grillage to the top platform, ensuring to fix the grillage into place with the grillage clips supplied.

Fixing the handrail

- First loosely fit the handrail stanchions. Having installed the handrail stanchions, fit the handrail tube & D-returns. Ensure internal jointers & all external fittings are fully engaged and the hex grub screws torque tightened to 39 Nm
- Complete a final level check on treads, platform and handrail stanchions and torque all M12 bolts to 100 Nm.

Using your measurements

A B C
we can identify the components that you require

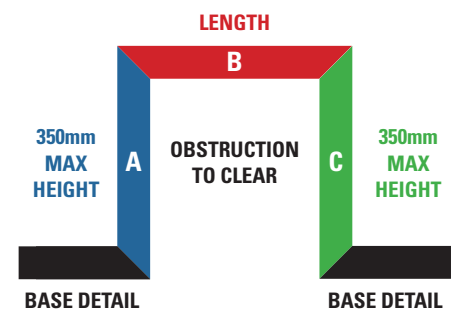

TREADS	HEIGHT A (mm)	HEIGHT C (mm)
1	287 - 407	287 - 407

PART	UP & ONTO PLATFORM up to (mm)
1	502
2	1002
3	1502
4	2002
5	

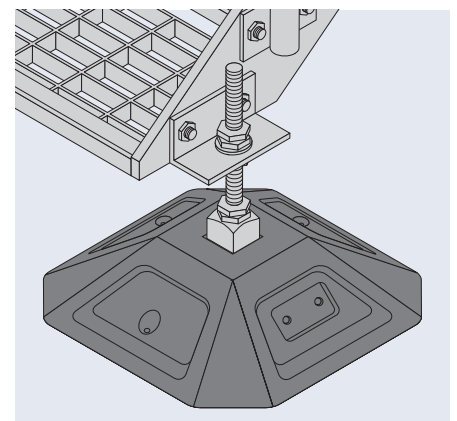

Rubber Feet base fixing

